



QUALITY FEEL FOR E-BRAKE SWITCH

INDUSTRY:
Automotive

APPLICATION:
Electronic Parking
Brake

COMPONENT:
Switch

LOCATION:
Europe



BACKGROUND

As vehicles incorporate increasingly sophisticated electric designs, more lubrication points are required to ensure lasting, trouble-free operation. An Automotive Tier 1 Supplier approached one of Nye's affiliates in search of a lubricant for their Electronic Parking Brake (EPB) switch. The supplier needed a plastic-compatible grease that would prevent wear, reduce noise, and convey a quality feel within their switch design.

CHALLENGE

- Can the lubricant extend the life of the switch while imparting a quality feel for drivers?

SOLUTION

RHEOLUBE[®] 362HB

A lithium soap thickened, light viscosity, synthetic hydrocarbon grease.

- Reduces noise, vibration, and harshness for a quality feel
- Compatible with most plastics and elastomers
- Stable over a wide temperature range, -40 to 125 °C
- Ideal for sliding or rolling components

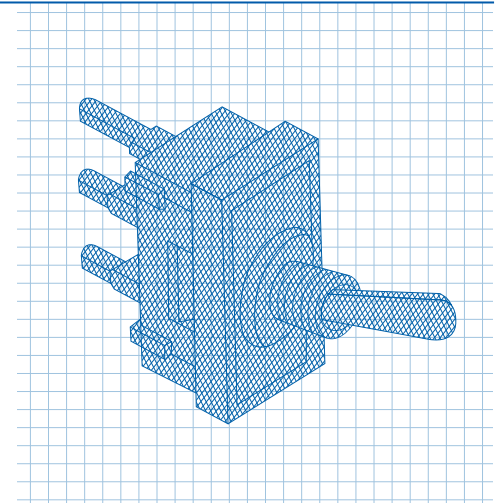

RESULTS

After in-house testing, the automotive tier supplier was pleased that Rheolube[®] 362HB reduced surface wear during EPB operation and met the functional life requirements of the OEM. The supplier was also pleased with the improved tactile feel provided by the grease.

Typical Properties

Base Oil Properties	Conditions	Rheolube® 362HB	Test Method
Chemistry	–	PAO/Lithium Soap	–
Temperature Range	–	-40 to 125 °C	–
Kinematic Viscosity	40 °C	32.6 cSt	ASTM D445
	100 °C	5.7 cSt	ASTM D445
Viscosity Index	–	135	ASTM D2270
Grease Properties			
Penetration (1/10 mm)	Unworked	292	ASTM D217
	Worked (60X)	280	ASTM D217
NLGI Grade	–	2	ASTM D217
Oil Separation	24 h, 100 °C	2.2%	ASTM D6184
Evaporation	24 h, 100 °C	0.1%	CTM*

*CTM: Nye Company Test Method

Since 1844: Our performance is reflected in the value we bring to our customers.

Nye Lubricants is a leader in the innovation, formulation and provision of synthetic lubricants, enabling and improving breakthrough products and critical new technologies. We bring proven experience, deep technical knowledge and customer focus to solve our customers' toughest challenges, adding tangible value to products in a wide range of industries and applications.

Nye Lubricants, Inc.

12 Howland Road
Fairhaven, MA 02719 USA
Ph: +1.508.996.6721
Email: contact@nyelubricants.com

NyeLubricants.com

